



Submersible Pump Monitor

The ATC Diversified Submersible Pump Monitor is a specialized control for monitoring the **shaft seal** and stator **temperature** of a **submersible pump motor**. Seal leakage is detected by either a resistive float switch or a pair of conductive probes installed in the seal cavity. Over-temperature is detected by a normally-closed-low temperature switch mounted on the stator. The over-temperature function incorporates a bistable relay that retains its position during power failures.

ORDERING INFORMATION

MODEL NUMBER	DESCRIPTION
SPM-120-AEE	Dual Function Alarm/Relay

SPECIFICATIONS

SUPPLY VOLTAGE	120 VAC, 50/60 Hz	
SENSOR VOLTAGE	12 VDC	
POWER REQUIRED	4 VA	
DUTY CYCLE	Continuous	
SENSITIVITY	Leakage	1k $\Omega$ to 35 k $\Omega$ adjustable
	Over-Temperature	Open Circuit
CONTACT RATING	(2) SPDT, 10 A @ 120 VAC Resistive	
LIFE EXPECTANCY	Mechanical	10 Million Operations
	Electrical	100,000 Operations @ Rated Load
INDICATORS	Green LED illuminates under normal conditions Red LED illuminates when leak is detected Red LED illuminates on over-temperature	
TEMPERATURE RATING	Operate	-4° to 131°F (-20° to +55°C)
	Storage	-40° to 185°F (-40° to +85°C)
RESPONSE TIMES	Leakage Trip	1 SEC
	Leakage Reset	1 SEC
	Temperature Trip	0.1 SEC
TERMINATIONS	(12) #8-32 Screw Terminals	
ENCLOSURE	Style "E" Lexan® Surface Mounted	
WEIGHT	17 oz.	

DIMENSIONS (INCHES)

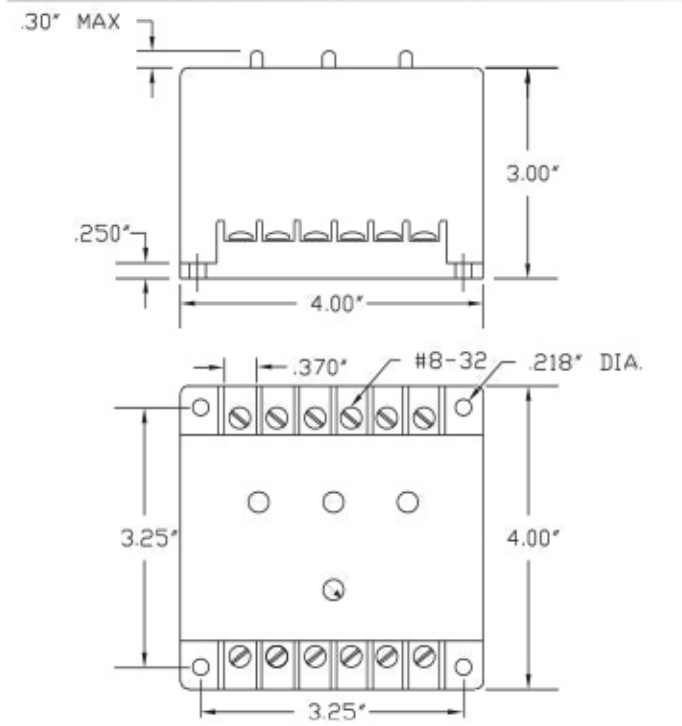

Special Controls // SPM Series

OPERATION

Figure 1 shows the connections for use with a Flygt model FLS float switch. The leakage sensitivity must be adjusted to 1 k for float switch applications. If a pair of conductive probes is used to sense seal leakage, a 100 k resistor is required as shown in Figure 2, and the sensitivity should be set to the desired value.

The states of the unit's relay outputs are determined by the series combination resistance of the leakage and temperature sensors. Under normal conditions the resistance remains between the leakage and over-temperature sensitivities, and both output relays are de-energized. If the temperature switch opens, the over-temperature relay latches on until the remote reset button is pressed. Two conditions must be met for reset to occur: power must be applied and the temperature switch must be closed. If the leakage sensor resistance drops below the leakage sensitivity setting, the leakage relay energizes. When the leakage condition clears, the relay resets automatically.

WIRING

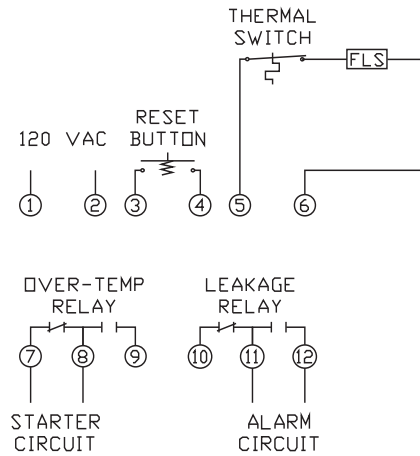

Fig. 1 FLS Connection

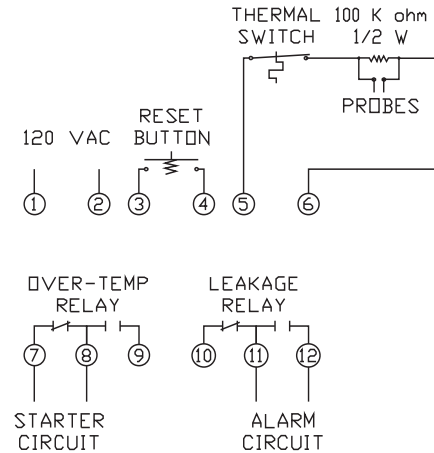

Fig. 2 Probe Connection